

Handicare **1100** stairlift

FOR STRAIGHT STAIRCASES



Unique Drive System Provides Elegant Look with Robust Performance

Right away, you will notice the slim profile of this stylish, yet powerful stairlift. Thanks to its patented 4-motor friction drive, there is no exposed gear rack resulting in a clean look and feel on your stairs. The 1100 model offers a variety of additional options including a powered seat swivel and footrest as well as unique solutions to eliminate trip hazards at the top and bottom landings. The Handicare 1100 from Savaria includes continuous charging on the rail with Easy Glide technology for gentle stops and a smooth enhanced ride quality.



With a great selection of upgrades, this stairlift addresses additional mobility concerns as well as common issues due to doors at the top and bottom landings.

 savaria®

Handicare 1100 | Straight Stairlift

Automatic Slide Track System



As you move up or down the stairs, the rail moves out of the way at the bottom and top landings eliminating a potential trip hazard. Available as an upgrade option.

Get More with the 1100



Enclosed rail

There is no exposed gear rack, providing an elegant and clean look on your stairs.



Easy hinge

Lightweight manual hinge with gas strut operation for use at lower landing.



Zero intrusion

Innovative bracket design to eliminate rail overrun at last stair.

Specifications

Applications	Residential indoor
Capacity	309 lb (140 kg) ¹
Nominal Speed	13 ft/min (0.07 m/s)
Drive/Motor	Patented multi-drive friction technology
Fold-up depth	12.6" (320 mm)
Fold-out depth	20.9" (530 mm)
Range of incline	30° to 50°
Warranty	24 months parts and limited lifetime on rail and powertrain ²
Standard Features	Vanilla beige wipe-clean upholstery, retractable seat belt, emergency stop button, obstruction sensors, non-slip footrest, continuous charge, battery powered for use during power failure, two remote controls, armrest control, keyed switch to prevent unauthorized use

¹ capacity reduces to 287 lb (130 kg) on incline over 46°, ² see dealer for complete details

Dimensions*

- A 2.4" (60 mm)
- B 15.4" (390 mm)
- C 22.6" (575 mm)
- D 17.7" (450 mm)
- E 15.7" (400 mm)
- F 16.9"–20.5" (430 mm–520 mm)
- G 2.75" (70 mm)

*Dimensions may vary depending on the angle of your stairs and specific installation

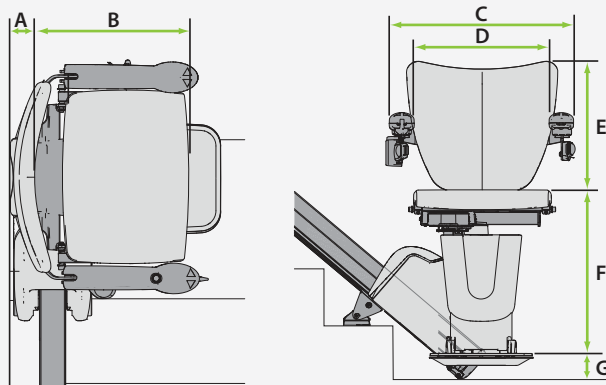

1.888.333.5023 savariahomeaccess.com

Authorized Dealer:

Savaria is a global leader in accessibility. We design and manufacture reliable commercial accessibility elevators, home elevators, wheelchair lifts and Handicare stairlifts. All of our products are made with the goal of helping people move – whether that's to overcome mobility challenges or to simply make life easier.